

ALU-FORK-MOUNTED-HOOK

Sample documentation:

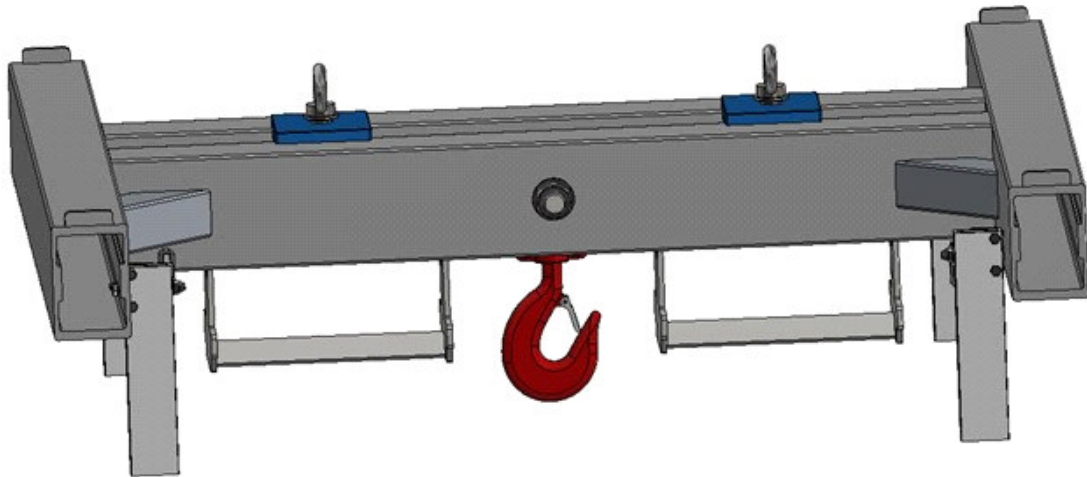

USER INFORMATION

The installation, operating and maintenance instructions for SCHILLING products must always be followed.

The instructions must be read carefully and fully understood by the users and/or their employees before using the product carefully read and fully understood before using the product.

Keep the user information for reuse!



Contents

1	Introduction	3
1.1	Manufacturer	3
1.2	Terms and Conditions	3
2	Presentation of information	4
2.1	Symbols and terminology.....	4
2.2	Instructions for use and enumerations.....	5
3	Declaration of Conformity	6
4	Safety	7
4.1	General safety notes	7
4.2	Approved use	8
4.3	Non approved use	8
5	Technical Data.....	9
6	General Data	10
6.1	The following data is engraved on the individual components of the Aluminium Gantry Crane:	10
7	Delivery and transport	11
7.1	Scope of delivery	11
7.2	Transportation	11
7.3	Storage	11
8	Overview of individual components of the Aluminium Fork Mounted Hook	12
9	Assembly	13
9.1	Fixing the aluminum Aluminium Fork Mounted Hook.....	13
10	Putting into operation	16
10.1	Compulsory prior inspection and testing.....	16
10.2	Visual inspection, function test.....	16
11	Operation	17
12	Maintenance.....	18
12.1	Maintenance plan	18
12.2	Visual inspection, function testing and stress testing.....	18
12.3	Inspection report / repeat inspection.....	19
12.4	Checklist	22
13	Disassembly and Disposal.....	23
13.1	Disassembly.....	23
13.2	Disposal	23
13.3	Disposal of packaging material	23

14	Service	24
14.1	Contact	24
14.2	Spare parts ordering or reordering process.....	24

1 Introduction

- ▲ The Aluminium Cross Beam is designed for lifting, lowering and moving of loads through use of a lifting device (e.g. Crane) and/or attachment points.
- ▲ This user information constitutes an integral part of the product and an element of the overriding risk assessment and handling instructions to be taken into account whenever lifting or handling loads.
- ▲ The user information must be available to all users.
- ▲ Please read this user information thoroughly before using the Aluminium Cross Beam.
- ▲ This user information explains how to safely assemble, operate, maintain, repair, disassemble and dispose of the Aluminium Cross Beam.
- ▲ In addition to this user information, you must also observe and comply with all applicable occupational health and safety regulations of the country and the environment in which the Aluminium Cross Beam is used as well as all other general regulations and rules regarding safe and appropriate use.
- ▲ Images and illustrations in this user information may differ from the actual product which will be supplied.
- ▲ Unauthorized modifications of the Aluminium Cross Beam or self-made auxiliary equipment are prohibited.

1.1 Manufacturer



1.2 Terms and Conditions

- ▲ In the event of direct sales transactions, the General Terms and Conditions can be obtained from the manufacturer or from their website.
- ▲ If you have purchased your device from an intermediary, please ask your distributor/salesperson

2 Presentation of information

This user information uses symbols, terminology, instructions for use and enumerations as described in Chapters 2.1 to 2.2 below.

2.1 Symbols and terminology

Safety notes

Safety notes are categorised and presented as follows:

HAZARD

A safety note designated as a “HAZARD” indicates a risk which will directly and with certainty lead to death or severe, permanent personal injury.

WARNING

A safety note designated as a “WARNING” indicates a risk which may lead to severe personal injury or death.

CAUTION

A safety note designated as a “CAUTION” indicates a risk which may lead to minor to moderate personal injury:

NOTE

A safety note designated as a “NOTE” indicates a risk which may lead to material damage.

Useful information and tips



INFO

This symbol indicates useful information and tips.

Disposal



INFORMATION FOR DISPOSAL

of packaging materials, lifting devices, etc.

2.2 Instructions for use and enumerations

All instructions for use are presented in chronological order and numbered, e.g.:

1. Step 1
2. Step 2

Outcomes of actions are indicated by an arrow:

- Outcome or device response

Instructions for use which do not have to be carried out in a particular sequence are indicated as follows:

1. Step 1
2. Step 2

Outcomes of actions are indicated by an arrow:

- Outcome or device response

Enumerations are indicated by indents:

- Enumeration

3 Declaration of Conformity

EC Declaration of Conformity

Pursuant to the EC Machinery Directive 2006/42/EC, Appendix II A

We hereby declare that the below mentioned machine complies with the general health and safety requirements of EC Directive 2006/42/EC in terms of its design and construction and in the version marketed by us.

This declaration shall become invalid in the event of modifications to the machine without our prior approval.

Manufacturer:

SCHILLING Kran- und Hebeteknik GmbH
Ernst-Zimmermann-Str. 9-11
88045 Friedrichshafen
Telefon: +49 (0) 7541 60404-0



Description and identification of the machine:

Designation: Aluminium Cross Beam for Big-Bag
Item number: **Sample documentation**
Serial number:
Load capacity:
Year of manufacture:

Applied harmonised standards, in particular:

- DIN EN 13001-1:2015 – Krane – Konstruktion allgemein – T1 Allgemeine Prinzipien und Anforderungen
- DIN EN 13001-2:2021 – Krane – Konstruktion allgemein – T2 Lasteinwirkungen
- EN 13155:2003+A2:2009 – Krane – Sicherheit – Lose Lastaufnahmemittel (Traversen)
- EN 16851:2017+A1:2020 - Krane - Leichtkransysteme

Manufacturer:

SCHILLING Kran- und Hebeteknik GmbH, Ernst-Zimmermann-Straße 9-11, 88045 Friedrichshafen, Deutschland

Signature:

Martin Schilling – Managing Director

Datum:

Authorized person for documentation: Danny Büdinger – Techniker (Maschinentechnik)

4 Safety

Please read the safety instructions below thoroughly before putting the product into operation.

Chapters 4.1 to 4.3 set out general rules of conduct to be adhered to when handling the product. Instructions in the following chapters highlighted with a  symbol must be followed in order to avoid putting persons and materials at risk. Safety notes pertaining to individual instructions for use are listed before the relevant step and must be observed.

4.1 General safety notes

- Read this user information in full.
- Observe the safety notes.
- Ensure that this user information is available at the site of operation at all times.
- The product must be operated by suitably qualified personnel (see Tab. 1) only.
- In addition to this user information, you must also observe and comply with all applicable occupational health and safety regulations of the relevant country and environment in which the product is used, as well as other general regulations for safe and appropriate use.
- Any damage compromising safety must be repaired immediately.
- Perform all work prudently.
- Never open a lifting device when loaded.
- Never stand/walk below the suspended load..
- Only load the safety load hooks (swivel hooks) straight, in alignment with their axis of rotation.

Qualifications required for handling lifting devices

Field of activity	Qualification	Specialist knowledge
Delivery and transport	Dealer, freight carrier	Proof of load securing instruction
Storage	Warehouse staff	Storage and retrieval of technical equipment
Assembly, disassembly	Qualified personnel	Professional experience in the assembly and dismantling of technical equipment.
Operation, simple visual inspection	Qualified personnel	Authorized person Knowledge of accident prevention regulations Qualified to sling loads independently
Maintenance, repair, commissioning	Specialists	Authorized specialist personnel with extended technical understanding. Knowledge of occupational safety and accident prevention regulations
Disposal	Qualified personnel	Knowledge of the regulations for proper disposal and reuse

Tab. 1: Overview

4.2 Approved use

- Lifting, lowering and moving of loads through use of a lifting device (e.g. Crane) and/or attachment points
- The stated load capacity must be observed
- Temperature ranges from -20° to +50°C
- Wind speeds of up to < 40 km/h

4.3 Non approved use

- Exceeding the maximum load capacity
- Structural modifications of the product
- Standing/walking below the suspended load
- Pulling a load diagonally
- Forcefully freeing loads that are stuck
- Dragging loads along the ground
- Transporting persons and animals

No guarantee is provided for the completeness of Chapter 4.3.

Anything that is not explicitly permitted is classified as non approved use.

5 Technical Data

Designation: Aluminium Cross Beam for Big-Bag

Total height:

Construction height:

Fork profile:

Item number: **Sample documentation**

Serial number:

Load capacity:

Year of manufacture:

Note:

Further information can be found under the article number in the enclosed documents or on our homepage.

6 General Data

6.1 The following data is engraved on the individual components of the Aluminium Gantry Crane:

Address label Manufacturer



Nominal load label



Example of a SCHILLING engraving:

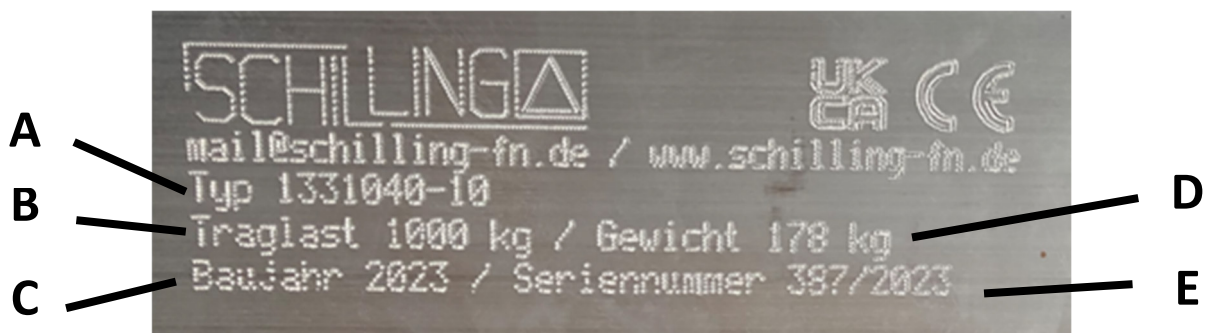

Explanation of the engraving details:

A: Type

B: Load capacity

C: Year of manufacture

D: Total weight

E: Serial number

7 Delivery and transport

7.1 Scope of delivery

Immediately check the delivery for completeness against the enclosed delivery note.

You may also use the overview of the product and the parts list in order to verify the completeness of the delivery (see Chapter 8).

If parts are missing, please contact your supplier immediately.

If notified late, especially if the product has already been used, we cannot accept any claims for after supply.

7.2 Transportation

The product is checked and adequately packaged prior to delivery

NOTE
<p>Damage to the device</p> <p>Incorrect transportation may damage the product.</p> <ul style="list-style-type: none">▪ Always transport the product as intended.▪ Use a suitable means of transport.▪ Make sure that the product is adequately secured during transportation.

7.3 Storage

NOTE
<p>Damage to the device</p> <p>Incorrect storage may damage the product.</p> <ul style="list-style-type: none">▪ Always store the product as intended.▪ Store the product in a clean and dry place.▪ Protect the product from:<ul style="list-style-type: none">- constant humidity or outdoor storage- contamination- damage- corrosion

8 Overview of individual components of the Aluminium Fork Mounted Hook

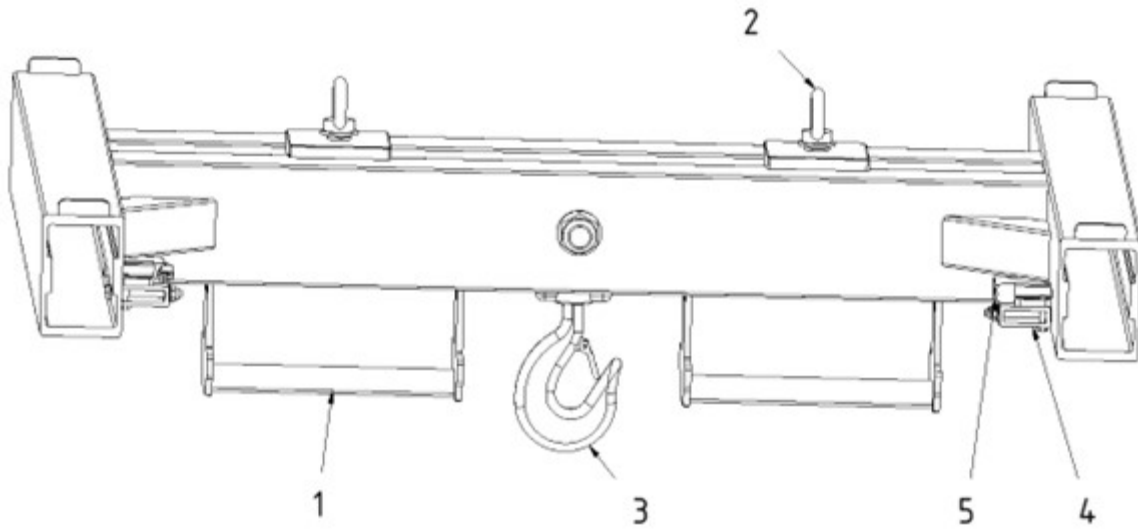

Part List

Item	Name	Quantity	Item	Name	Quantity
1	Forklift shoe	2	4	Folding foot	4
2	Eyebolt	2	5	Spring bolt	4
3	Safety load hook	1			

9 Assembly



INFO

The Aluminium Fork Mounted Hook will be delivered fully mounted

⚠ CAUTION

The Aluminium Fork Mounted Hook has pinching points which may cause injuries. Perform all assembly work prudently and cautiously.

9.1 Fixing the aluminum Aluminium Fork Mounted Hook

- On the forks of the forklift truck (1.1.)
- On another suitable lifting device (1.3.)

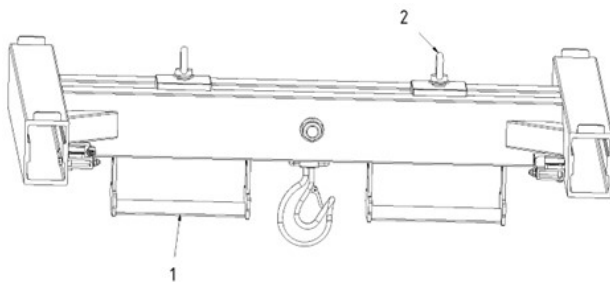

1. Fixing the Aluminium Fork Mounted Hook to the Forks of the forklift.

1.1.

Adjust the spacing of the forklift shoes (1) to the width of the forklift forks by loosening the 2 eyebolts (2) and moving the forklift shoes (1).

1.2.

Drive the forklift at an adjusted speed into the forklift shoes (1) of the Aluminium Fork Mounted Hook.

1.3.

Fix the Aluminium Fork Mounted Hook on the forks of the forklift by tightening the 2 eyebolts (2).

1.4.

Check that the Aluminium Fork Mounted Hook fits on the forks of the forklift.

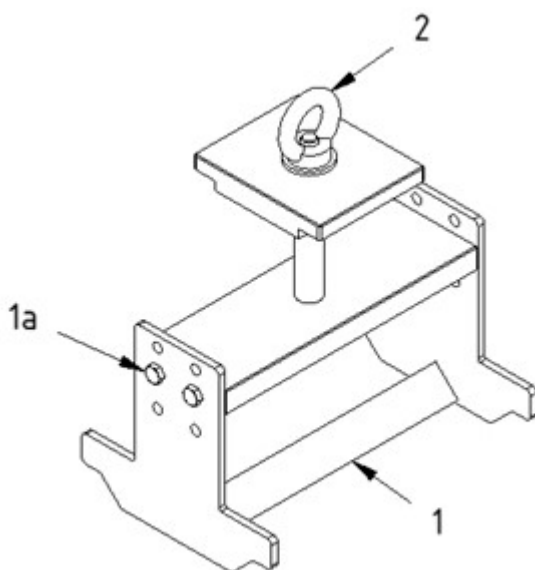

1.2 Presetting the forklift shoe:

1.2.1.

You can preset the height of the forklift shoes (1) by loosening the two screws (1a) and presetting them at the top, middle or bottom, depending on the height of the forklift tines.

1.2.2.

Once you have determined the correct position, refasten the two screws (1a) and tighten them.

⚠ CAUTION

The Aluminium Fork Mounted Hook has pinching points which may cause injuries. Perform all assembly work prudently and cautiously.

Load attachment points

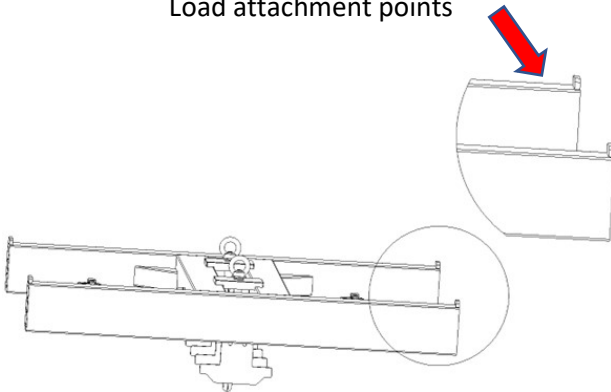

2. attaching the load to the aluminum load beam:

2.1.

Attach the big bag to the 4 designated points on the aluminum load crossbar.

2.2.

Slightly lift the aluminum load beam with the attached big bag.

2.3.

Check that the big bag is securely attached to the aluminum load crossbar.

If the Big-Bag is tilted, lower the Big-Bag again and adjust the suspension so that the Big-Bag hangs horizontally.

Note the center of gravity of the load.

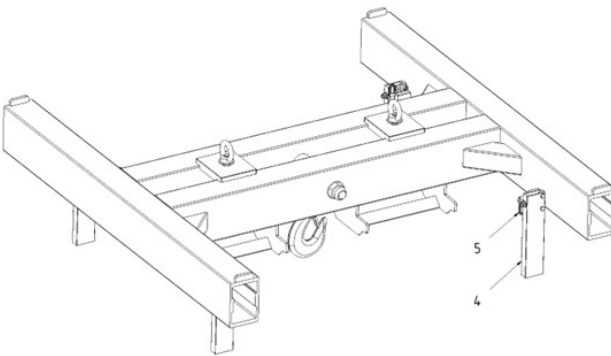

3. parking the aluminum load beam:

3.1.

Pull out the spring latch (5) of the aluminum lifting beam and fold out the folding foot (4).

Engage the spring latch (5) again.

3.2.

Repeat step 3.1. until all 4 folding feet (4) are folded out.

3.3.

When all folding feet (4) are folded out, you can put the aluminum load crossbar down.

⚠ DANGER

The eyebolts (2) are not intended for lifting loads. They are merely fastening elements.

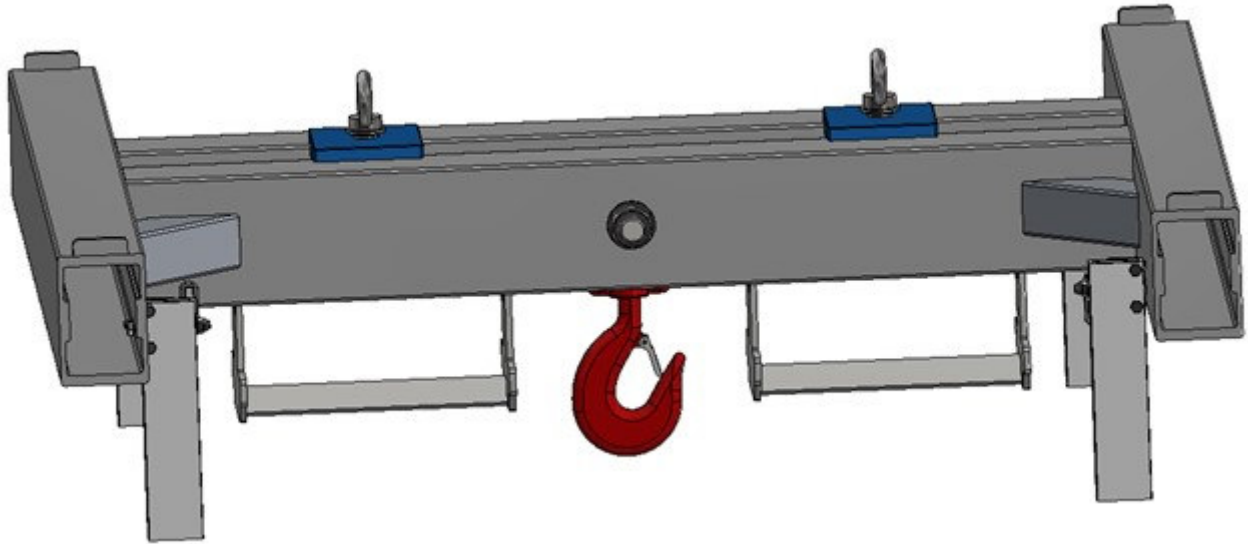

- Die Alu-Big-Bag-Traverse wird bereits vollständig montiert angeliefert

10 Putting into operation

10.1 Compulsory prior inspection and testing

Inspection and testing of the Aluminium Fork Mounted Hook is required prior to commissioning in order to ensure that the Aluminium Fork Mounted Hook is in perfect working order and ready for its intended use.

WARNING

Without prior inspection and testing, injuries may occur during commissioning.
Inspect and the Aluminium Fork Mounted Hook as follows:

- Visual inspection
- Function test

10.2 Visual inspection, function test

Visual inspection

The aluminum load beam must be checked before each new start-up.

CAUTION

The Aluminium Fork Mounted Hook has pinching points which may cause injuries.

- Perform all inspections and testing of the Aluminium Fork Mounted Hook prudently and cautiously.

1. Only suitable lifting equipment and/or slings may be used.
2. The load must hang securely and horizontally.
3. Operation must be discontinued in the event of defects. Defects may only be repaired professionally.
With appropriate design:
4. the pins on the safety load hook bracket must be inserted into the holes in the cross members.
5. the star knob screws of the cross beams must be engaged in the locking holes of the main cross beam.
6. the hexagon socket screws at the end of the main beam must be tightened.

Function test

The aluminum load beam must be tested every time before putting it back into operation

WARNING

Loads may fall in the event of deformation and wear of individual components.

- Take the Aluminium Fork Mounted Hook out of operation immediately.
- Have the device inspected and tested by a qualified expert.

1. Verify to what extent the individual components are still functional.
2. If in doubt, replace individual components.
3. Verify that all movable parts are able to move freely.
4. Replace parts which do not move freely.
5. Put the Aluminium Fork Mounted Hook out of operation if no longer functional or damaged beyond repair.
6. Dispose of the individual material components (see Chapter 13).

11 Operation

The Aluminium Fork Mounted Hook can be used as intended once it has been properly assembled and put into operation.

CAUTION

The Aluminium Fork Mounted Hook has pinching points which may cause injuries.

- Operate the Aluminium Fork Mounted Hook prudently and carefully.

WARNING

Various hazards may occur in connection with the Aluminium Fork Mounted Hook.

- The Aluminium Fork Mounted Hook may only be mounted on the two matching forks of a forklift.
- If the fixing of the Aluminium Fork Mounted Hook at the lifting forks of the forklift is not firm, the entire Aluminium Fork Mounted Hook can slip off the forklift.
- The load can slip if the Aluminium Fork Mounted Hook is extremely inclined.
- If the load is not correctly hooked onto the Aluminium Fork Mounted Hook, the load may fall.
- Dangerous situations can occur when the load swings through the movement. Prevent the load from swinging.
- The load must not touch the ground when moving with the forklift so that no horizontal forces act on the Aluminium Fork Mounted Hook.
- If cracks are detected in welding seams, a load-bearing part may break, causing the load to fall and people to be seriously injured.

DANGER

Never work below a load on Aluminium Fork Mounted Hook.

- Never stand/walk below the suspended load.

The Aluminium Fork Mounted Hook is used for lifting, lowering and moving loads of suitable size by using a forklift.

12 Maintenance

The product is essentially maintenance free.

12.1 Maintenance plan

Maintenance date	Action
Prior to putting into operation	Visual inspection and function testing by qualified personnel
Prior to each subsequent operation, after initial putting into operation without any prior extraordinary incidents	Visual inspection by qualified personnel
Annually	Visual inspection, function testing and stress test performed by a qualified expert

Do not use concentrated acids or alkalis for cleaning, especially for non-metallic components. Do not use solvent-based cleaners here either.

12.2 Visual inspection, function testing and stress testing

Visual inspection

See chapter Putting into operation → Visual inspection

Function testing

See chapter Putting into operation → Function testing

Stress testing according to the relevant guidelines

The product must be subjected to stress tests at least once a year, and immediately in the event of modifications or repairs.

WARNING

Operators of the product are required to comply with statutory regulations.

- Have the device professionally inspected by a qualified expert (see Chapter 12.3)

1. Operators of the product must ensure that the product is inspected by a qualified expert at least once a year and that any faults identified during these inspections are eliminated immediately.
2. (Where applicable) The guidelines of the DGUV Vorschrift (regulations) 52 (BGV D6) – UVV Krane (cranes), must be observed.

12.3 Inspection report / repeat inspection

The date of the next outstanding inspection must be entered.

The maximum interval is 1 year

Shorter if used intensively in a suitable environment

Manufacturer: SCHILLING Kran- und Hebetchnik GmbH – http://www.schilling-fn.de	
Ernst-Zimmermann-Str. 9-11	
88045 Friedrichshafen	
Product	Aluminium Cross Beam for Big-Bag
Load capacity:	
Item numberr:	Sample documentation
Serial number:	
Year of manufacture:	

1.)	Inspection prior to delivery. Visual inspection and function testing of the product and its components have been performed. The product has been developed, constructed and built in accordance with the rules of engineering.
Date:	Date of dispatch (see delivery bill)
	Owner's/Manufacturer's signature

2.)	Commissioning test / start of use The test has been carried out
Date:	
	Signature of the qualified expert

3.)	Due date of the next repeat inspection	Date:
Inspection has been performed		
Date:		Signature of the qualified expert

4.)	Due date of the next repeat inspection	Date:
Repeat inspection Inspection has been performed		
Date:		Signature of the qualified expert

5.)	Due date of the next repeat inspection	Date:
-----	--	-------

Repeat inspection Inspection has been performed	
Date:	Signature of the qualified expert

6.) Due date of the next repeat inspection	Date:
Repeat inspection Inspection has been performed	
Date:	Signature of the qualified expert

7.) Due date of the next repeat inspection	Date:
Repeat inspection Inspection has been performed	
Date:	Signature of the qualified expert

8.) Due date of the next repeat inspection	Date:
Repeat inspection Inspection has been performed	
Date:	Signature of the qualified expert

9.) Due date of the next repeat inspection	Date:
Repeat inspection Inspection has been performed	
Date:	Signature of the qualified expert

10.) Due date of the next repeat inspection	Date:
Repeat inspection Inspection has been performed	
Date:	Signature of the qualified expert

11.) Due date of the next repeat inspection	Date:
---	-------

Repeat inspection Inspection has been performed	
Date:	Signature of the qualified expert

12.) Due date of the next repeat inspection	Date:
Repeat inspection Inspection has been performed	
Date:	Signature of the qualified expert

13.) Due date of the next repeat inspection	Date:
Repeat inspection Inspection has been performed	
Date:	Signature of the qualified expert

14.) Due date of the next repeat inspection	Date:
Repeat inspection Inspection has been performed	
Date:	Signature of the qualified expert

15.) Due date of the next repeat inspection	Date:
Repeat inspection Inspection has been performed	
Date:	Signature of the qualified expert

16.) Due date of the next repeat inspection	Date:
Repeat inspection Inspection has been performed	
Date:	Signature of the qualified expert

Continue the list yourself if required

12.4 Checklist

Test template for duplication. File the completed copy with the documentation

Product: Aluminium Cross Beam for Big-Bag			
Load capacity:			
Item number: Sample documentation			
Serial number:			
Year of manufacture:			
Manufacturer: SCHILLING Kran- und Hebetchnik GmbH – http://www.schilling-fn.de Ernst-Zimmermann-Straße 9-11 – 88045 Friedrichshafen			
Test instructions, if components are present. No claim to completeness.			
ok	Not ok	not relevant	Test result ok, components in proper condition? List can / must be continued accordingly.
			Good general condition
			Load-bearing profiles, beams, struts free of cracks, without influencing damage?
			Screw and plug connections tight and in good order?
			Holes not worn out?
			Plastic elements no relevant cracks? No embrittlement?
			Chains, ropes, straps without visible damage?
			Documentation available, labels and markings present and legible?
			Load test carried out?
If there are defects, these must be rectified by the manufacturer or a specialist company using original spare parts. The defects have been professionally rectified and the product is ready for use:			
Date and signature of the plant manager:			
The product is free of defects and can be used until the next test:			
Date and signature of the examining expert:			

13 Disassembly and Disposal

As manufacturers, we are required by law to inform you not to dispose of the product as unsorted waste. Dispose of it separately via collection and return points for industrial and commercial waste.

The product must therefore be disassembled into its individual components.

13.1 Disassembly

CAUTION

Disassembly of the product on unstable surfaces or by means of unsuitable tools may result in injuries.

1. The assembled product is disassembled in the reverse order to that described in Chapter 9.
2. The individual assemblies of the product must then be disassembled by means of a suitable tool.

13.2 Disposal



INFORMATION FOR DISPOSAL

If the product is no longer functional or cannot be repaired, it must be disposed of in accordance with the applicable regulations.

The product consists of several different material components which must be disposed of separately:

1. Dispose of aluminium components as scrap aluminium.
2. Dispose of metal components as scrap metal.
3. Dispose of plastic components as scrap plastic.
4. Dispose of electrical components as electrical scrap (when using an electrical chain hoist).

13.3 Disposal of packaging material



INFORMATION FOR DISPOSAL

Packaging material must be correctly disposed of or recycled.

14 Service

14.1 Contact

For service matters or all other enquiries, please contact your supplier.

14.2 Spare parts ordering or reordering process

**INFO**

Please use the overview and table in Chapter 8 for better identification of the required component and submit this to your supplier.

1. Determine the serial number of your product. The serial number can be found in this user information in Chapter 3. The serial number is also engraved on the product.
2. Determine the year of manufacture of the product. The year of manufacture can be found in this user information in Chapter 3. The year of manufacture is also engraved on the product.
3. Use the overview in Chapter 8 and highlight the component or assembly in question.
4. Then contact your supplier directly, submitting the collected data and any other details.

